

ACRYLIC SERIES

Features and Specifications:

- Double equal bowl kitchen sink
- Manufactured from an ultra high density, 100% pure acrylic resin
- Manufactured by thermoforming using heat and vacuum
- Underside reinforced with an FRP backing
- 1-1/4" x 3/4" machined resin matrix rim
- Can only be installed in new countertops, not existing countertops with existing sink cutout
- Undermount installation required. May not be top mounted.
- This sink may be bonded seamlessly into solid surface and laminate
- This sink may be undermounted in all stone products. 1/8" overhang recommended
- Heat, scratch and chip resistant
- Stain and thermal shock proof
- Available colors: Bisque and White
- Supplied without mounting adhesive, clips or template
- Digital templates for CNC machines are available at www.karran.com
- Strainer baskets shown not included with sink.

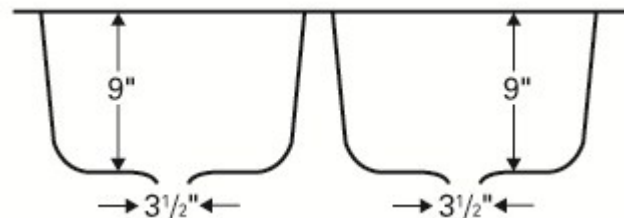
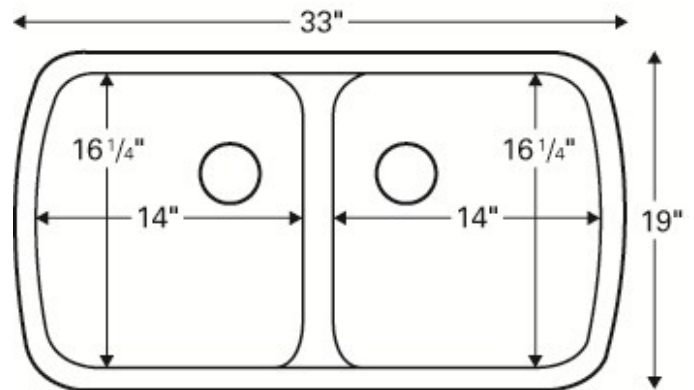
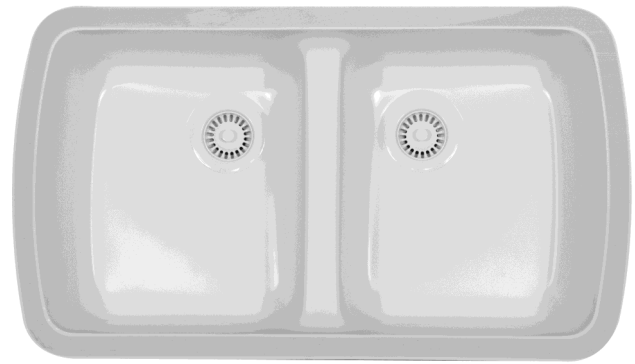

Compliance Certifications:

- Meets or exceeds:
ANSI Z124.6
CAN/CSA B45



Dimensions:

Outside: 33" x 19" x 9-1/4"
 Inside left bowl: 14" x 16-1/4" x 9"
 Inside right bowl: 14" x 16-1/4" x 9"
 Approx. weight unboxed: 26lbs

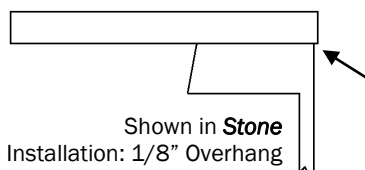
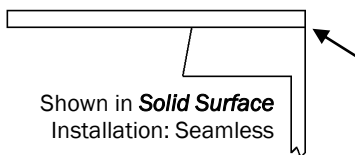
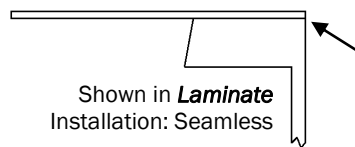

Acrylic Series Sink Installed in Laminate



Acrylic Series Sink Installed in Solid Surface



Karran, your source for seamless integration.

Features and Specifications:

- Double equal bowl kitchen sink
- Manufactured from an ultra high density, 100% pure acrylic resin
- Manufactured by thermoforming using heat and vacuum
- Underside reinforced with an FRP backing
- 1-1/4" x 3/4" machined resin matrix rim
- Can only be installed in new countertops, not existing countertops with existing sink cutout
- Undermount installation required. May not be top mounted.
- This sink may be bonded seamlessly into solid surface and laminate
- This sink may be undermounted in all stone products. 1/8" overhang recommended
- Heat, scratch and chip resistant
- Stain and thermal shock proof
- Available colors: Bisque and White
- Supplied without mounting adhesive, clips or template
- Digital templates for CNC machines are available at www.karran.com
- Strainer baskets shown not included with sink.

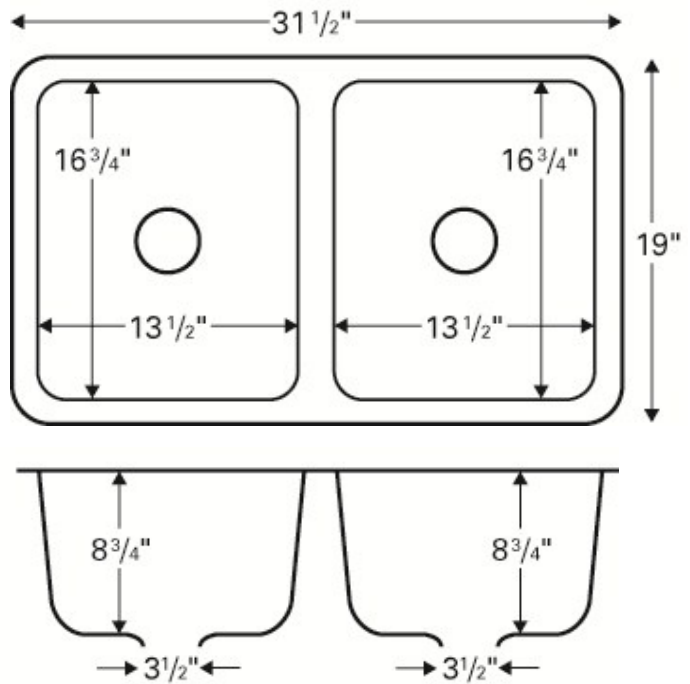

Compliance Certifications:

- Meets or exceeds:
ANSI Z124.6
CAN/CSA B45



Dimensions:

Outside: 31-1/2" x 19" x 9"
 Inside left bowl: 13-1/2" x 16-3/4" x 8-3/4"
 Inside right bowl: 13-1/2" x 16-3/4" x 8-3/4"
 Approx. weight unboxed: 25lbs

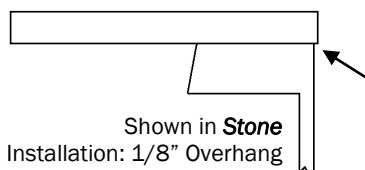
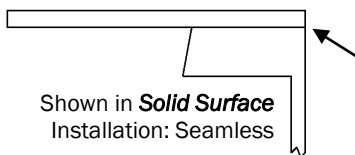
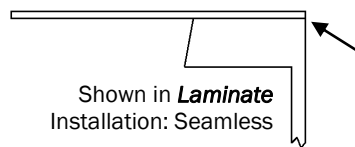

Acrylic Series Sink Installed in Laminate



Acrylic Series Sink Installed in Solid Surface



Karran, your source for seamless integration.

Features and Specifications:

- Double unequal bowl kitchen sink
- Manufactured from an ultra high density, 100% pure acrylic resin
- Manufactured by thermoforming using heat and vacuum
- Underside reinforced with an FRP backing
- 1-1/4" x 3/4" machined resin matrix rim
- Can only be installed in new countertops, not existing countertops with existing sink cutout
- Undermount installation required. May not be top mounted.
- This sink may be bonded seamlessly into solid surface and laminate
- This sink may be undermounted in all stone products. 1/8" overhang recommended
- Heat, scratch and chip resistant
- Stain and thermal shock proof
- Available colors: Bisque and White
- Supplied without mounting adhesive, clips or template
- Digital templates for CNC machines are available at www.karran.com
- Strainer baskets shown not included with sink.

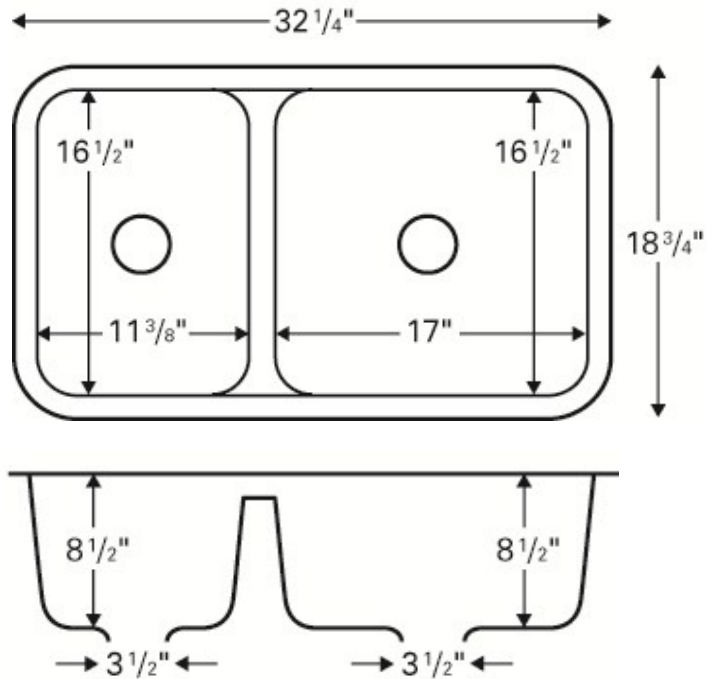

Compliance Certifications:

- Meets or exceeds:
ANSI Z124.6
CAN/CSA B45



Dimensions:

Outside: 32-1/4" x 18-3/4" x 8-3/4"
 Inside left bowl: 11-3/8" x 16-1/2" x 8-1/2"
 Inside right bowl: 17" x 16-1/2" x 8-1/2"
 Approx. weight unboxed: 25lbs

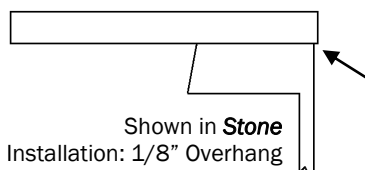
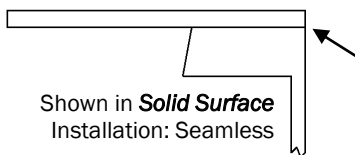
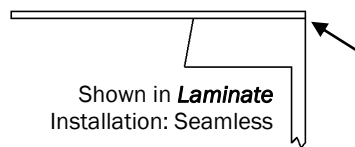

Acrylic Series Sink Installed in Laminate



Acrylic Series Sink Installed in Solid Surface



Karran, your source for seamless integration.

Features and Specifications:

- Double equal bowl kitchen sink
- Manufactured from an ultra high density, 100% pure acrylic resin
- Manufactured by thermoforming using heat and vacuum
- Underside reinforced with an FRP backing
- 1-1/4" x 3/4" machined resin matrix rim
- Can only be installed in new countertops, not existing countertops with existing sink cutout
- Undermount installation required. May not be top mounted.
- This sink may be bonded seamlessly into solid surface and laminate
- This sink may be undermounted in all stone products. 1/8" overhang recommended
- Heat, scratch and chip resistant
- Stain and thermal shock proof
- Available colors: Bisque and White
- Supplied without mounting adhesive, clips or template
- Digital templates for CNC machines are available at www.karran.com
- Strainer baskets shown not included with sink.

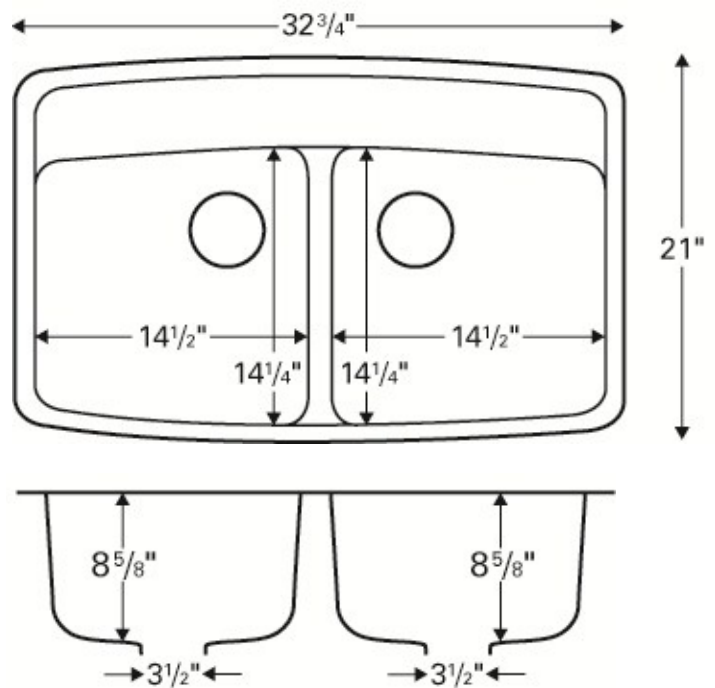

Compliance Certifications:

- Meets or exceeds:
ANSI Z124.6
CAN/CSA B45

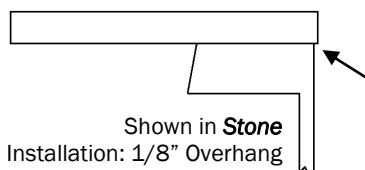
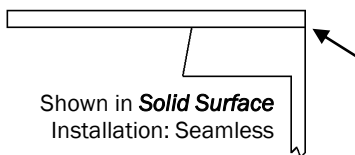
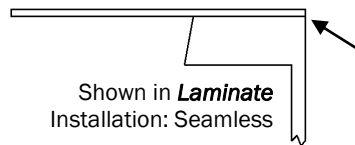

Dimensions:

Outside: 32-3/4" x 21" x 9"
 Inside left bowl: 14-1/2" x 14-1/4" x 8-5/8"
 Inside right bowl: 14-12" x 14-14" x 8-5/8"
 Approx. weight unboxed: 26lbs

Acrylic Series Sink Installed in Laminate



Acrylic Series Sink Installed in Solid Surface



Karran, your source for seamless integration.

Features and Specifications:

- Large/small bowl kitchen sink
- Manufactured from an ultra high density, 100% pure acrylic resin
- Manufactured by thermoforming using heat and vacuum
- Underside reinforced with an FRP backing
- 1-1/4" x 3/4" machined resin matrix rim
- Can only be installed in new countertops, not existing countertops with existing sink cutout
- Undermount installation required. May not be top mounted.
- This sink may be bonded seamlessly into solid surface and laminate
- This sink may be undermounted in all stone products. 1/8" overhang recommended
- Heat, scratch and chip resistant
- Stain and thermal shock proof
- Available colors: Bisque and White
- Supplied without mounting adhesive, clips or template
- Digital templates for CNC machines are available at www.karran.com
- Strainer baskets shown not included with sink.

Compliance Certifications:

- Meets or exceeds:
ANSI Z124.6
CAN/CSA B45

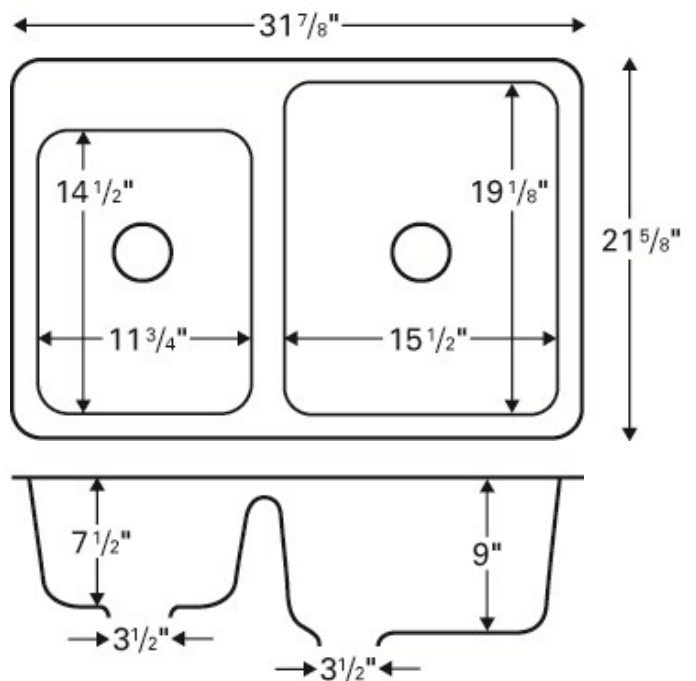
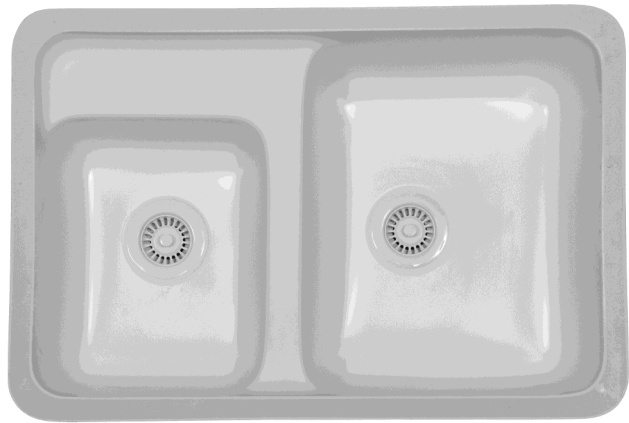

Dimensions:

Outside: 31-7/8" x 21-5/8" x 9-1/4"
 Inside left bowl: 11-3/4" x 14-1/2" x 7-1/2"
 Inside right bowl: 15-1/2" x 19-1/8" x 9"
 Approx. weight unboxed: 27lbs
 Reverse model: Landin

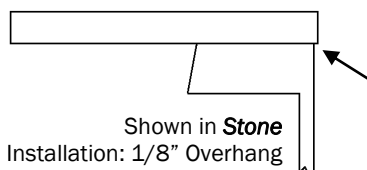
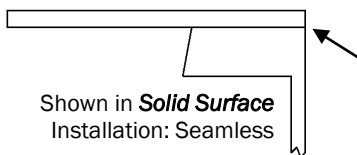
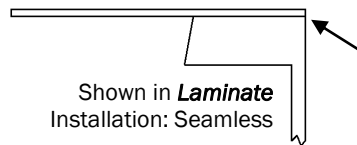

Acrylic Series Sink Installed in Laminate



Acrylic Series Sink Installed in Solid Surface



Karran, your source for seamless integration.

Features and Specifications:

- Double equal bowl kitchen sink
- Manufactured from an ultra high density, 100% pure acrylic resin
- Manufactured by thermoforming using heat and vacuum
- Underside reinforced with an FRP backing
- 1-1/4" x 3/4" machined resin matrix rim
- Can only be installed in new countertops, not existing countertops with existing sink cutout
- Undermount installation required. May not be top mounted.
- This sink may be bonded seamlessly into solid surface and laminate
- This sink may be undermounted in all stone products. 1/8" overhang recommended
- Heat, scratch and chip resistant
- Stain and thermal shock proof
- Available colors: Bisque and White
- Supplied without mounting adhesive, clips or template
- Digital templates for CNC machines are available at www.karran.com
- Strainer baskets shown not included with sink.

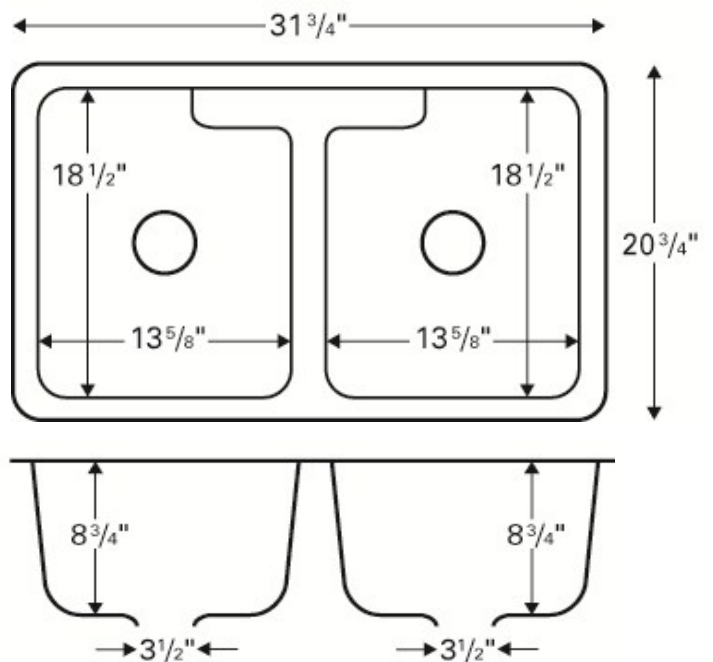
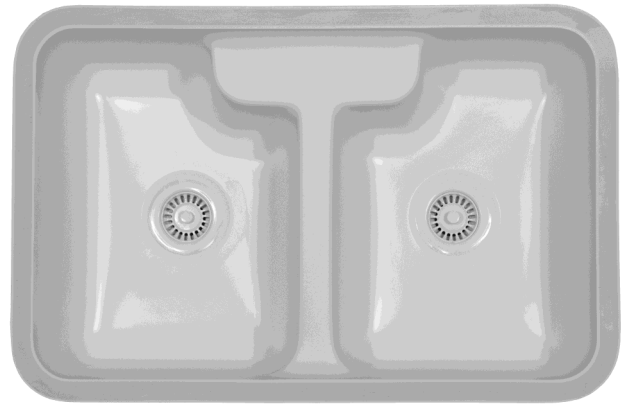

Compliance Certifications:

- Meets or exceeds:
ANSI Z124.6
CAN/CSA B45



Dimensions:

Outside: 31-3/4" x 20-3/4" x 9"
 Inside left bowl: 13-5/8" x 18-1/2" x 8-3/4"
 Inside right bowl: 13-5/8" x 18-1/2" x 8-3/4"
 Approx. weight unboxed: 27lbs

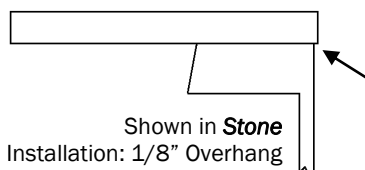
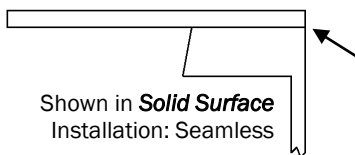
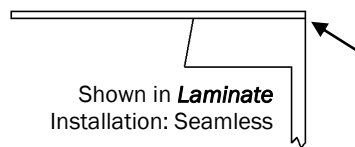

Acrylic Series Sink Installed in Laminate



Acrylic Series Sink Installed in Solid Surface



Karran, your source for seamless integration.

Features and Specifications:

- Large/small bowl kitchen sink
- Manufactured from an ultra high density, 100% pure acrylic resin
- Manufactured by thermoforming using heat and vacuum
- Underside reinforced with an FRP backing
- 1-1/4" x 3/4" machined resin matrix rim
- Can only be installed in new countertops, not existing countertops with existing sink cutout
- Undermount installation required. May not be top mounted.
- This sink may be bonded seamlessly into solid surface and laminate
- This sink may be undermounted in all stone products. 1/8" overhang recommended
- Heat, scratch and chip resistant
- Stain and thermal shock proof
- Available colors: Bisque and White
- Supplied without mounting adhesive, clips or template
- Digital templates for CNC machines are available at www.karran.com
- Strainer baskets shown not included with sink.

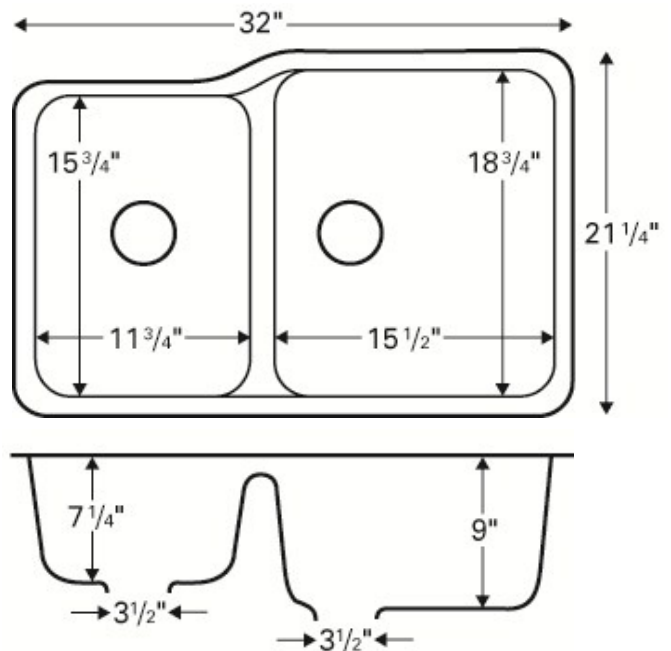
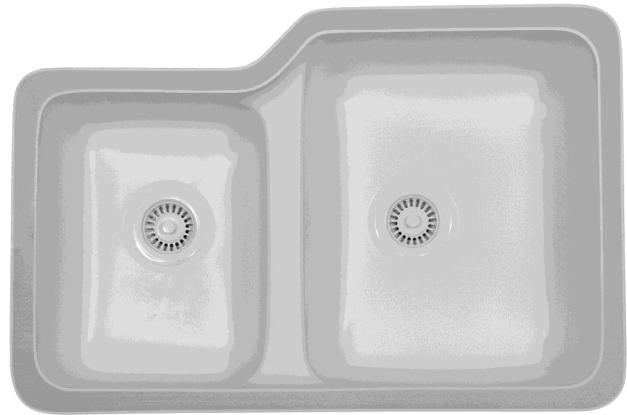

Compliance Certifications:

- Meets or exceeds:
ANSI Z124.6
CAN/CSA B45



Dimensions:

Outside: 32" x 21-1/4" x 9-1/4"
 Inside left bowl: 11-3/4" x 15-3/4" x 7-1/4"
 Inside right bowl: 15-1/2" x 18-3/4" x 9"
 Approx. weight unboxed: 27lbs
 Reverse model: Sorrento

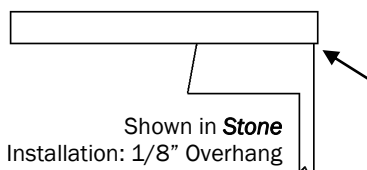
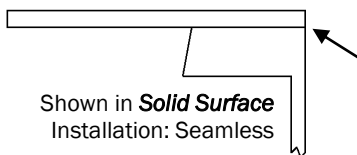
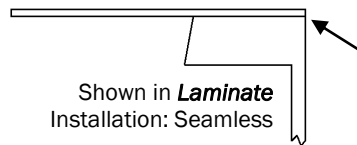

Acrylic Series Sink Installed in Laminate



Acrylic Series Sink Installed in Solid Surface



Karran, your source for seamless integration.

Features and Specifications:

- Extra-large single bowl kitchen sink
- Manufactured from an ultra high density, 100% pure acrylic resin
- Manufactured by thermoforming using heat and vacuum
- Underside reinforced with an FRP backing
- 1-1/4" x 3/4" machined resin matrix rim
- Can only be installed in new countertops, not existing countertops with existing sink cutout
- Undermount installation required. May not be top mounted.
- This sink may be bonded seamlessly into solid surface and laminate
- This sink may be undermounted in all stone products. 1/8" overhang recommended
- Heat, scratch and chip resistant
- Stain and thermal shock proof
- Available colors: Bisque and White
- Supplied without mounting adhesive, clips or template
- Digital templates for CNC machines are available at www.karran.com
- Strainer baskets shown not included with sink.

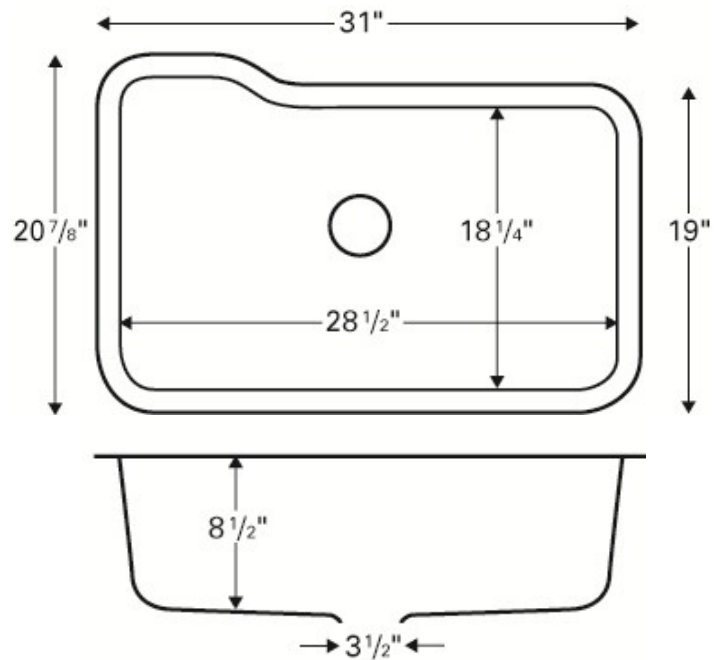

Compliance Certifications:

- Meets or exceeds:
ANSI Z124.6
CAN/CSA B45



Dimensions:

Outside: 31" x 20-7/8" x 8-3/4"
Inside: 28-1/2" x 18-1/4" x 8-1/2"
Approx. weight unboxed: 25lbs

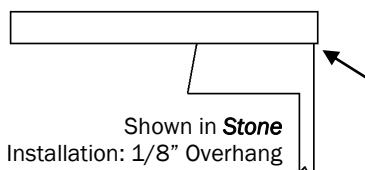
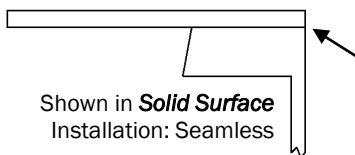
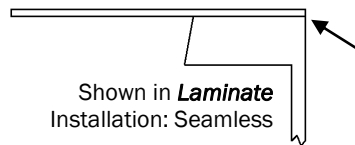

Acrylic Series Sink Installed in Laminate



Acrylic Series Sink Installed in Solid Surface



Karran, your source for seamless integration.

Features and Specifications:

- Large single bowl kitchen sink
- Manufactured from an ultra high density, 100% pure acrylic resin
- Manufactured by thermoforming using heat and vacuum
- Underside reinforced with an FRP backing
- 1-1/4" x 3/4" machined resin matrix rim
- Can only be installed in new countertops, not existing countertops with existing sink cutout
- Undermount installation required. May not be top mounted.
- This sink may be bonded seamlessly into solid surface and laminate
- This sink may be undermounted in all stone products. 1/8" overhang recommended
- Heat, scratch and chip resistant
- Stain and thermal shock proof
- Available colors: Bisque and White
- Supplied without mounting adhesive, clips or template
- Digital templates for CNC machines are available at www.karran.com
- Strainer baskets shown not included with sink.

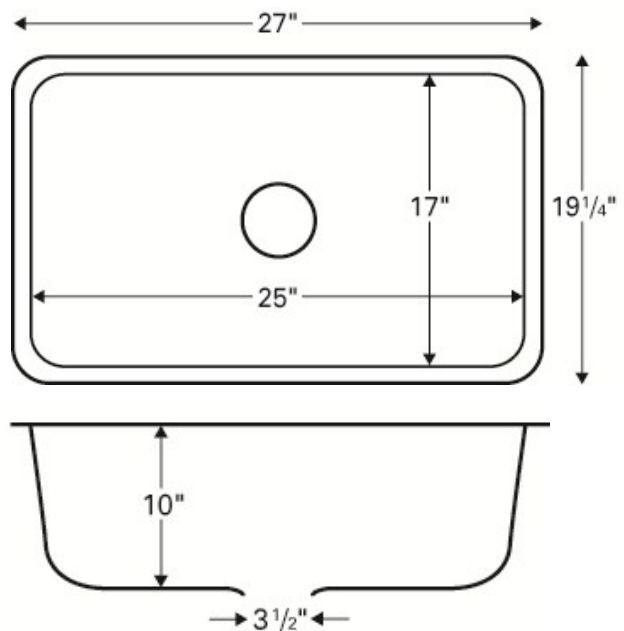
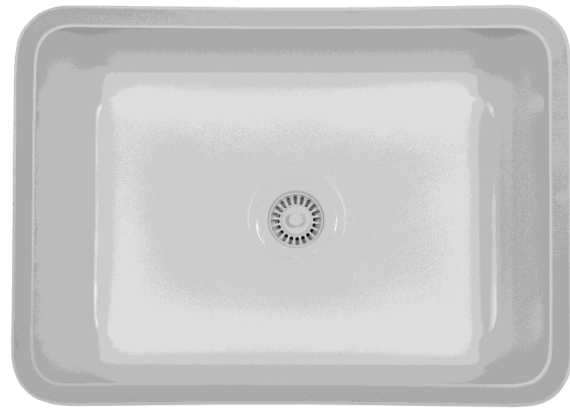

Compliance Certifications:

- Meets or exceeds:
ANSI Z124.6
CAN/CSA B45



Dimensions:

Outside: 27" x 19-1/4" x 10-1/4"

Inside: 25" x 17" x 10"

Approx. weight unboxed: 24lbs

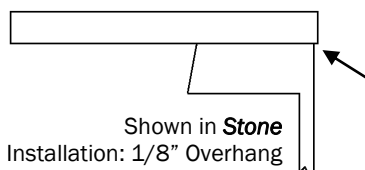
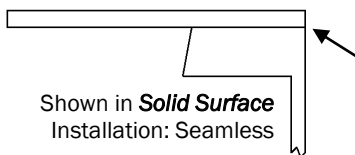
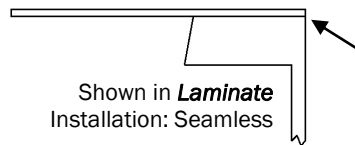

Acrylic Series Sink Installed in Laminate



Acrylic Series Sink Installed in Solid Surface



Karran, your source for seamless integration.

Features and Specifications:

- D-shaped single bowl kitchen sink
- Manufactured from an ultra high density, 100% pure acrylic resin
- Manufactured by thermoforming using heat and vacuum
- Underside reinforced with an FRP backing
- 1-1/4" x 3/4" machined resin matrix rim
- Can only be installed in new countertops, not existing countertops with existing sink cutout
- Undermount installation required. May not be top mounted.
- This sink may be bonded seamlessly into solid surface and laminate
- This sink may be undermounted in all stone products. 1/8" overhang recommended
- Heat, scratch and chip resistant
- Stain and thermal shock proof
- Available colors: Bisque and White
- Supplied without mounting adhesive, clips or template
- Digital templates for CNC machines are available at www.karran.com
- Strainer baskets shown not included with sink.

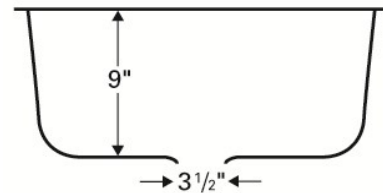
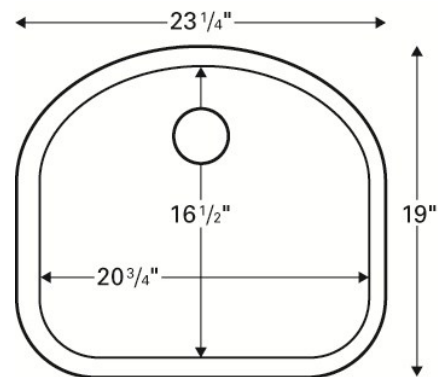

Compliance Certifications:

- Meets or exceeds:
ANSI Z124.6
CAN/CSA B45



Dimensions:

Outside: 23-1/4" x 19" x 9-1/4"
 Inside: 20-3/4" x 16-1/2" x 9"
 Approx. weight unboxed: 20lbs

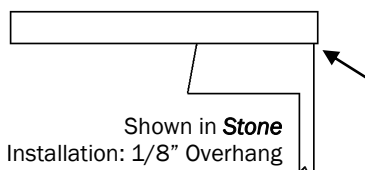
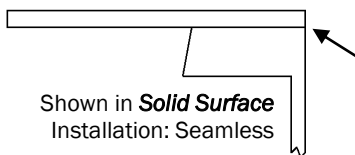
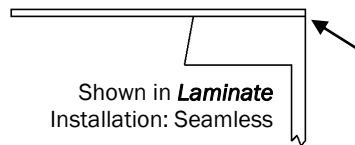

Acrylic Series Sink Installed in Laminate



Acrylic Series Sink Installed in Solid Surface



Karran, your source for seamless integration.

Features and Specifications:

- Single bowl kitchen sink
- Manufactured from an ultra high density, 100% pure acrylic resin
- Manufactured by thermoforming using heat and vacuum
- Underside reinforced with an FRP backing
- 1-1/4" x 3/4" machined resin matrix rim
- Can only be installed in new countertops, not existing countertops with existing sink cutout
- Undermount installation required. May not be top mounted.
- This sink may be bonded seamlessly into solid surface and laminate
- This sink may be undermounted in all stone products. 1/8" overhang recommended
- Heat, scratch and chip resistant
- Stain and thermal shock proof
- Available colors: Bisque and White
- Supplied without mounting adhesive, clips or template
- Digital templates for CNC machines are available at www.karran.com
- Strainer baskets shown not included with sink.

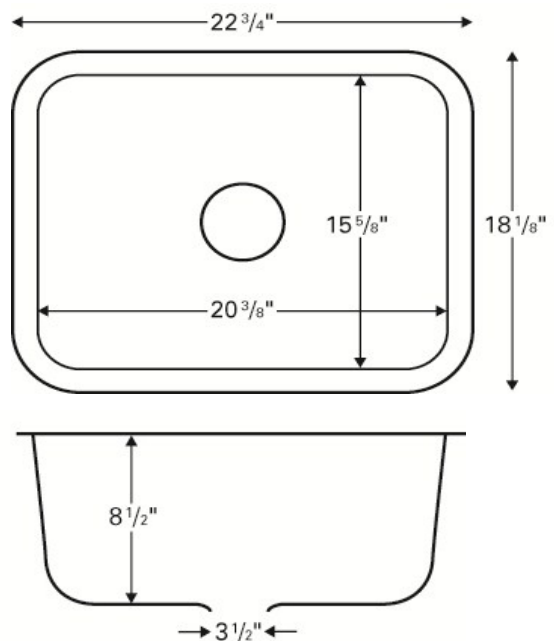
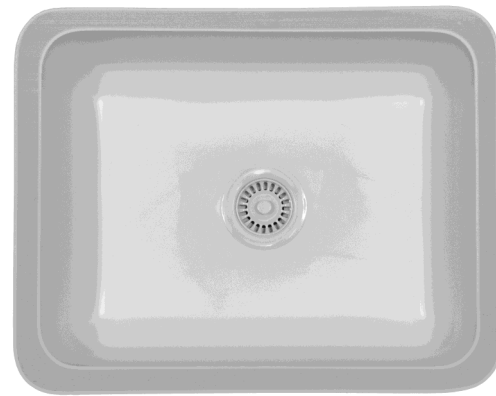

Compliance Certifications:

- Meets or exceeds:
ANSI Z124.6
CAN/CSA B45



Dimensions:

Outside: 22-3/4" x 18-1/8" x 8-3/4"
 Inside 20-3/8" x 15-5/8" x 8-1/2"
 Approx. weight unboxed: 20lbs

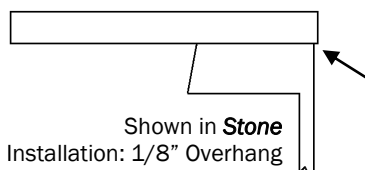
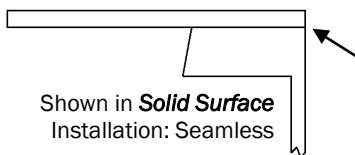
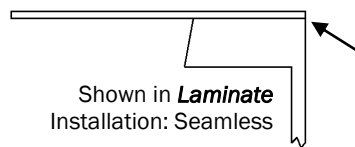

Acrylic Series Sink Installed in Laminate



Acrylic Series Sink Installed in Solid Surface



Karran, your source for seamless integration.

Features and Specifications:

- Single bowl laundry sink
- Manufactured from an ultra high density, 100% pure acrylic resin
- Manufactured by thermoforming using heat and vacuum
- Underside reinforced with an FRP backing
- 1-1/4" x 3/4" machined resin matrix rim
- Can only be installed in new countertops, not existing countertops with existing sink cutout
- Undermount installation required. May not be top mounted.
- This sink may be bonded seamlessly into solid surface and laminate
- This sink may be undermounted in all stone products. 1/8" overhang recommended
- Heat, scratch and chip resistant
- Stain and thermal shock proof
- Available colors: Bisque and White
- Supplied without mounting adhesive, clips or template
- Digital templates for CNC machines are available at www.karran.com
- Strainer baskets shown not included with sink.

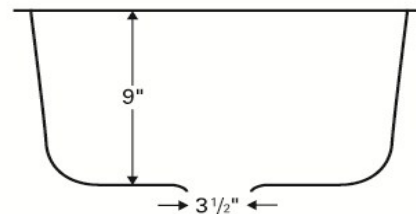
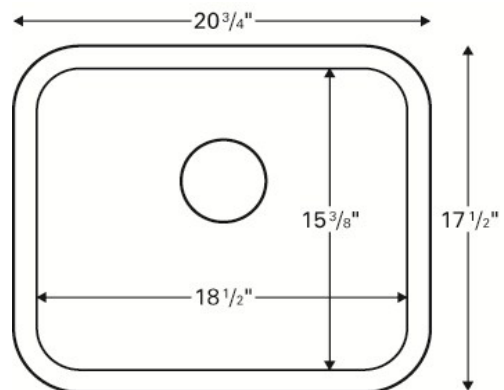
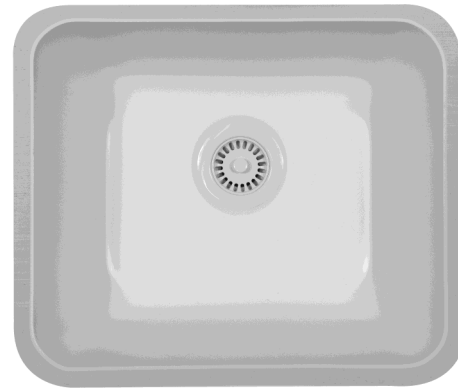

Compliance Certifications:

- Meets or exceeds:
ANSI Z124.6
CAN/CSA B45



Dimensions:

Outside: 20-3/4" x 17-1/2" x 9-1/4"
 Inside: 18-1/2" x 15-3/8" x 9"
 Approx. weight unboxed: 18lbs

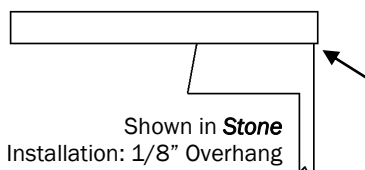
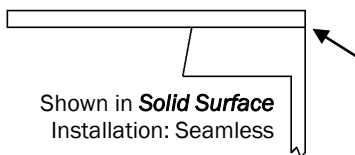
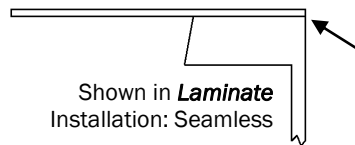

Acrylic Series Sink Installed in Laminate



Acrylic Series Sink Installed in Solid Surface



Karran, your source for seamless integration.

Features and Specifications:

- Bar/prep sink
- Manufactured from an ultra high density, 100% pure acrylic resin
- Manufactured by thermoforming using heat and vacuum
- Underside reinforced with an FRP backing
- 1-1/4" x 3/4" machined resin matrix rim
- Can only be installed in new countertops, not existing countertops with existing sink cutout
- Undermount installation required. May not be top mounted.
- This sink may be bonded seamlessly into solid surface and laminate
- This sink may be undermounted in all stone products. 1/8" overhang recommended
- Heat, scratch and chip resistant
- Stain and thermal shock proof
- Available colors: Bisque and White
- Supplied without mounting adhesive, clips or template
- Digital templates for CNC machines are available at www.karran.com
- Strainer baskets shown not included with sink.

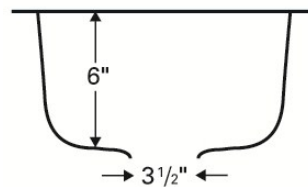
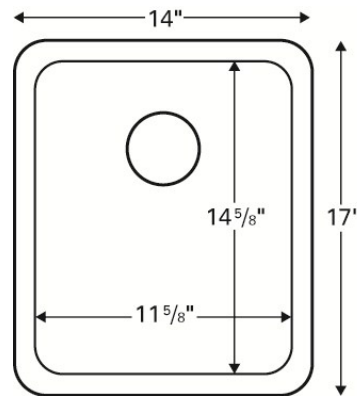
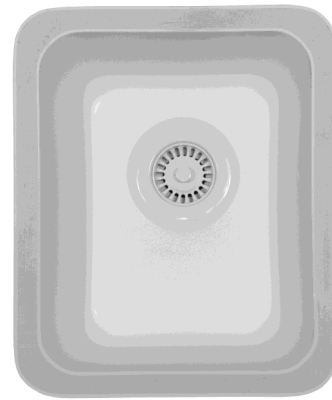

Compliance Certifications:

- Meets or exceeds:
ANSI Z124.6
CAN/CSA B45



Dimensions:

Outside: 14" x 17" x 6-1/4"
 Inside: 11-5/8" x 14-5/8" x 6"
 Approx. weight unboxed: 14lbs

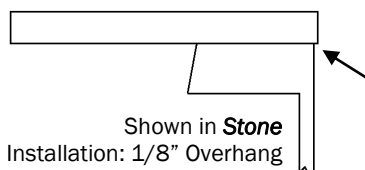
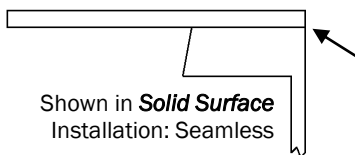
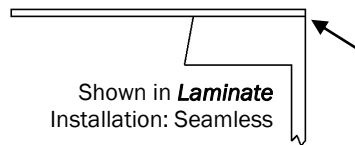

Acrylic Series Sink Installed in Laminate



Acrylic Series Sink Installed in Solid Surface



Karran, your source for seamless integration.

Features and Specifications:

- Vanity sink
- Manufactured from an ultra high density, 100% pure acrylic resin
- Manufactured by thermoforming using heat and vacuum
- Underside reinforced with an FRP backing
- 1-1/4" x 3/4" machined resin matrix rim
- Can only be installed in new countertops, not existing countertops with existing sink cutout
- Undermount installation required. May not be top mounted.
- This sink may be bonded seamlessly into solid surface and laminate
- This sink may be undermounted in all stone products. 1/8" overhang recommended
- Heat, scratch and chip resistant
- Stain and thermal shock proof
- Available colors: Bisque and White
- Supplied without mounting adhesive, clips or template
- Digital templates for CNC machines are available at www.karran.com
- Strainer baskets shown not included with sink.
- No integrated overflow. Kit available.

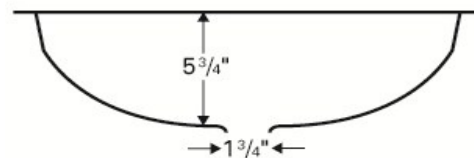
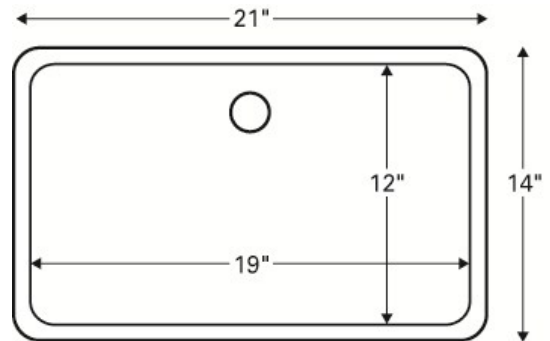
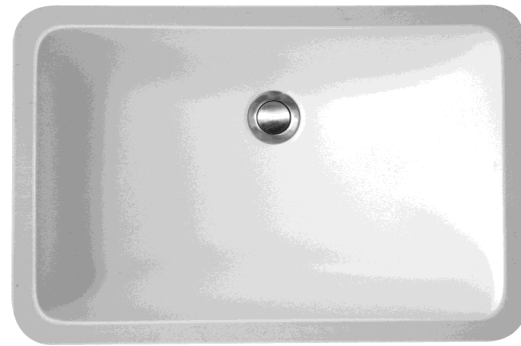

Compliance Certifications:

- Meets or exceeds:
ANSI Z124.6
CAN/CSA B45



- ADA Compliant

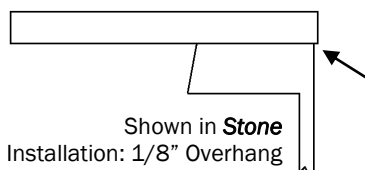
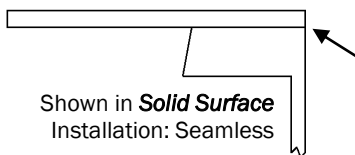
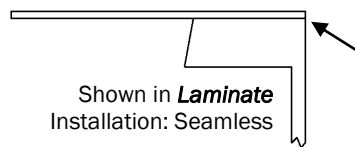

Dimensions:

Outside: 21" x 14 x 6"
 Inside: 19" x 12" x 5-3/4"
 Approx. weight unboxed: 12lbs

Acrylic Series Sink Installed in Laminate



Acrylic Series Sink Installed in Solid Surface



Karran, your source for seamless integration.

Features and Specifications:

- Vanity sink
- Manufactured from an ultra high density, 100% pure acrylic resin
- Manufactured by thermoforming using heat and vacuum
- Underside reinforced with an FRP backing
- 1-1/4" x 3/4" machined resin matrix rim
- Can only be installed in new countertops, not existing countertops with existing sink cutout
- Undermount installation required. May not be top mounted.
- This sink may be bonded seamlessly into solid surface and laminate
- This sink may be undermounted in all stone products. 1/8" overhang recommended
- Heat, scratch and chip resistant
- Stain and thermal shock proof
- Available colors: Bisque and White
- Supplied without mounting adhesive, clips or template
- Digital templates for CNC machines are available at www.karran.com
- Strainer baskets shown not included with sink.
- May be ordered with integrated overflow

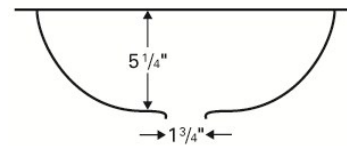
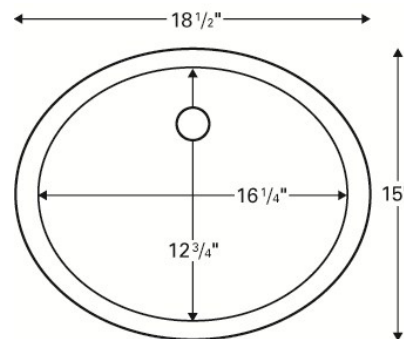
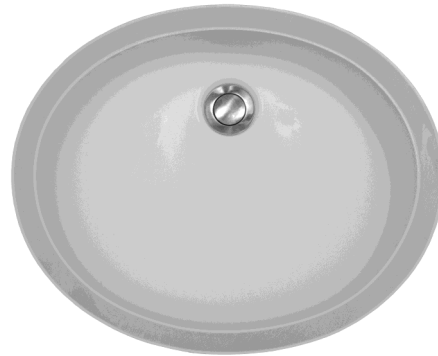

Compliance Certifications:

- Meets or exceeds:
ANSI Z124.6
CAN/CSA B45



- ADA Compliant

Dimensions:

Outside: 18-1/2" x 15" x 5-3/4"
 Inside: 16-1/4" x 12-3/4" x 5-1/4"
 Approx. weight unboxed: 11lbs

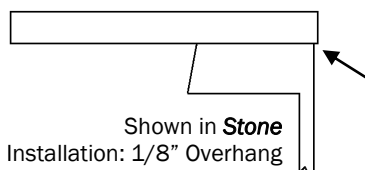
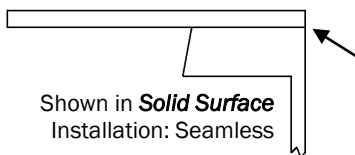
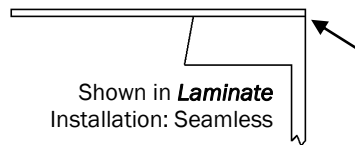

Acrylic Series Sink Installed in Laminate



Acrylic Series Sink Installed in Solid Surface



Karran, your source for seamless integration.

Features and Specifications:

- Vanity sink
- Manufactured from an ultra high density, 100% pure acrylic resin
- Manufactured by thermoforming using heat and vacuum
- Underside reinforced with an FRP backing
- 1-1/4" x 3/4" machined resin matrix rim
- Can only be installed in new countertops, not existing countertops with existing sink cutout
- Undermount installation required. May not be top mounted.
- This sink may be bonded seamlessly into solid surface and laminate
- This sink may be undermounted in all stone products. 1/8" overhang recommended
- Heat, scratch and chip resistant
- Stain and thermal shock proof
- Available colors: Bisque and White
- Supplied without mounting adhesive, clips or template
- Digital templates for CNC machines are available at www.karran.com
- Strainer baskets shown not included with sink.
- No integrated overflow. Kit available.

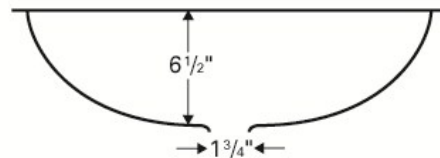
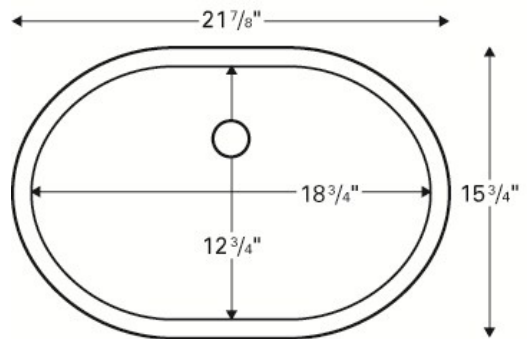

Compliance Certifications:

- Meets or exceeds:
ANSI Z124.6
CAN/CSA B45



Dimensions:

Outside: 21-7/8" x 15-3/4" x 6-3/4"
 Inside: 18-3/4" x 12-3/4" x 6-1/2"
 Approx. weight unboxed: 14lbs

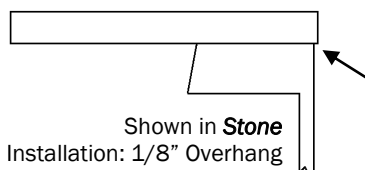
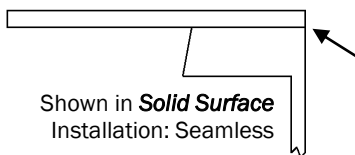
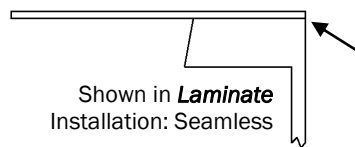

Acrylic Series Sink Installed in Laminate



Acrylic Series Sink Installed in Solid Surface



Karran, your source for seamless integration.

Features and Specifications:

- Vanity sink
- Manufactured from an ultra high density, 100% pure acrylic resin
- Manufactured by thermoforming using heat and vacuum
- Underside reinforced with an FRP backing
- 1-1/4" x 3/4" machined resin matrix rim
- Can only be installed in new countertops, not existing countertops with existing sink cutout
- Undermount installation required. May not be top mounted.
- This sink may be bonded seamlessly into solid surface and laminate
- This sink may be undermounted in all stone products. 1/8" overhang recommended
- Heat, scratch and chip resistant
- Stain and thermal shock proof
- Available colors: Bisque and White
- Supplied without mounting adhesive, clips or template
- Digital templates for CNC machines are available at www.karran.com
- Strainer baskets shown not included with sink.
- No integrated overflow. Kit available.

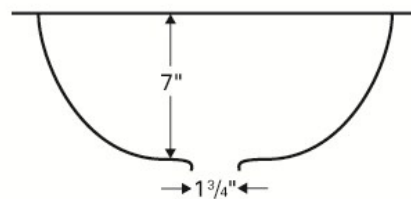
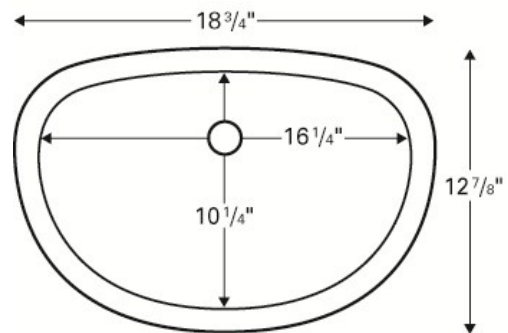

Compliance Certifications:

- Meets or exceeds:
ANSI Z124.6
CAN/CSA B45



Dimensions:

Outside: 18-3/4" x 12-7/8" x 7-1/4"

Inside: 16-1/4" x 10-1/4" x 7"

Approx. weight unboxed: 11lbs

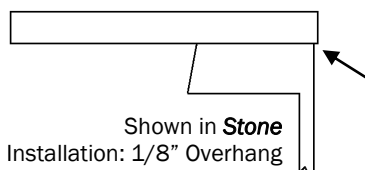
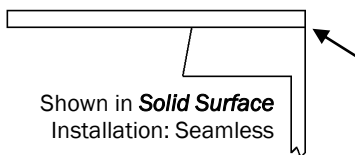
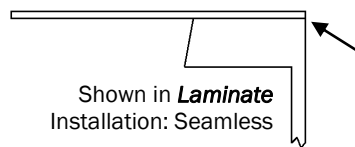

Acrylic Series Sink Installed in Laminate



Acrylic Series Sink Installed in Solid Surface



Karran, your source for seamless integration.